



CONTACT

Quality Leader in
Truck Attachments

○ Drum handlers

○ Self powered attachments

○ Lifting devices and booms

○ Wide load handling

○ Recycling containers

○ Premises cleaning

○ Fall prevention cages

○ Truck forks



Contact Attachments
Mochdre Industrial Estate
Newtown
Powys
SY16 4LE

tel : 01686 611200
fax : 01686 611201

Carriage Mounted Drum Handler

The entry level, carriage mounted solution for handling Steel Drums



Use :-

Designed for handling standard "big-bags", this carriage mounted attachment gives increased lift height, the tines being set at the top of the carriage plate. The bags are picked up by pushing a tine through the loops on each corner of the bag.

Ordering Information :-

- Truck Capacity?
- Carriage Class?
- Drum Type?
- Drum Weight?

Model Ref.	Weight	C of G	LLC
CDH-1	40 kg	114 mm	190 mm
CDH-1 HD	49 kg	121 mm	200 mm
CDH-2	59 kg	122 mm	190 mm



Type 1, Steel

Drum Types =

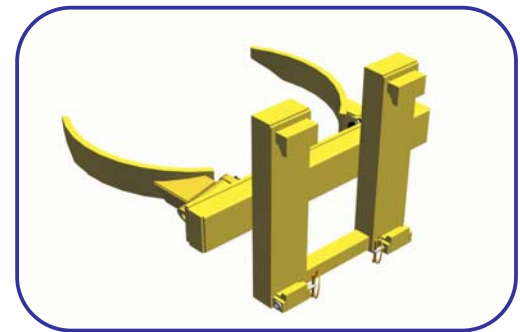

Model Ref.	Capacity	Carriage Class	No. of drums	Drum Types	A	B
CDH-1	500 kg	2	1	1	400 mm	500 mm
CDH-1 HD	1000 kg	2	1	1	400 mm	500 mm
CDH-2	1000 kg	2	2	1	400 mm	500 mm

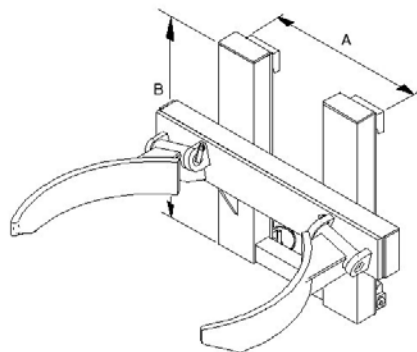

Operation :-

The action of the attachment is fully automatic. The attachment has two curved arms which hinge at one end. To lift a drum, approach it with the clamp arms horizontal and positioned halfway up the drum, between two rolling hoops. When the arms contact the drum they will open automatically, falling back around the drum as you proceed forwards. When the attachment is raised the arms will grip the drum tightly under the upper rolling hoop.

www.forklift-attachments.co.uk
email : sales@forklift-attachments.co.uk

Freephone
0800
028 3332

Call now for your personal
quote and further info

